



Illustrative photo

The centralised bypass is an alternative to the distributed bypass. Technically the two solutions fulfil the same purpose, i.e. to guarantee power continuity, but have different architectures.

Whilst it is true that distributed bypass solutions are the most common due to their flexibility of use and low initial cost, it is also true that in the medium/large data centre market centralised bypass solutions are preferable in terms of technical performance, footprint and sometimes cost, above all in large installations where the number and type of protections as well as system wiring have an impact.

The data centre and data-storage market in general is destined for large growth. It is therefore important to respond to the various requirements with flexible solutions that are able to adapt to the growing demands of the market in terms of the levels of power and performance required.

### Flexibility

The Riello UPS centralised bypass (named MSB) is available in four standard power ratings: 800, 1200, 2000 and 3000 kVA.

Intermediate solutions within this range can be made, as well as solutions greater than 3000 kVA based on the requirements of the customer or application.

The MSB centralised bypass can be integrated with the Master HP range; in fact it can be associated with up to 7 UPS modules in the range, obviously without static bypass and associated bypass line (named MHU). Based on requirements, MSB can also be compatible with the Master MPS range, thus ensuring complete flexibility aimed at satisfying all power and power supply requirements.

Riello UPS provides the same flexibility as the Master HP for the battery bus, so that the MHU units can operate with both shared or separate batteries.

The 800 kVA MSB is supplied with a comprehensive cabinet including bypass line input switch (SWBY), system output switch (SWOUT) and manual bypass (SWMB).

The 1200 kVA model is supplied as standard without any switches but can be equipped with the same, suitably proportioned, switches provided for the 800 kVA model (SWBY, SWOUT, SWMB).

The more powerful models are supplied with no switches; the bulky sizes of disconnection devices at these power levels are such as to favour tailor-made engineering solutions as an additional part of the system attestation and distribution cabinets where the centralised bypass and MHU modules are fitted.

### The ideal solution for installations with UPS in parallel greater than 1 MVA

Medium-high power systems are often comprised of N UPS of small-medium power ratings arranged in parallel. It is clear that the larger the size of the individual UPS modules or the number of units configured in parallel, the more complex and extensive the system wiring shall be. Particular attention should be paid to the length of the power lines for the individual UPS bypasses, so that they are equidistant from the common points. Even minimal variations in the line impedances of the individual bypasses can cause current equipartition problems between the UPS and associated overcurrent in the cables whenever they supply from the bypass. This can lead to the inappropriate cut-in of protection devices and can generate heat, with the end result of minimising power continuity and increasing power

consumption for cooling the system.

The Riello UPS centralised bypass (MSB) is the ideal solution for eliminating all critical issues connected with power distribution over bypass lines. When activated, all power flows through a single static bypass module, ensuring:

- High reliability
- Improved energy efficiency
- Exceptional ability to withstand short-circuits downstream of the system
- Centralised system control both with regards to accessibility to system information and with regards to manoeuvrability since the system is equipped with a single manual system bypass.

By opting for the solution with a centralised bypass, the individual MHU units are provided without integrated static bypasses, thus eliminating critical components (static circuit and associated line protections such as disconnectors and/or fuses). This translates into a lower installation cost by eliminating the cables for the auxiliary power supply lines to the individual modules.

These advantages grow exponentially as the power levels at play and number of modules increase. This is why the centralised bypass solution is technically and economically preferable for power levels above one megawatt.

### High system reliability

When compared to a solution with a distributed bypass and a considerable number of UPS modules arranged in parallel (more than 4), the MSB solution significantly reduces the amount of components (SCR, switches, control elements for individual static bypasses, coupling inductances),

consequently increasing system reliability.

### Power supply from bypass line: "On Line" mode

Recent design philosophies for data centres are pushing towards making systems operate on bypass lines not only in the event of an emergency, but as an alternative to "ON-Line" mode, thus improving system efficiency. For this reason power circulation through a single line (centralised bypass), eliminates all problems connected with current distribution, which must be ensured in the event of the operation of UPS modules in parallel with distributed by-passes. The greater the power rating of the UPS, the exponentially greater the risk of minimal impedance differences in the bypass lines generating large imbalances in current circulation, with a serious risk of protection cut-in, compromising power supply continuity. With the centralised bypass the static circuit is single and independent and the current flows through a single channel, ensuring immunity from interaction problems between individual UPS units.

### Power supply from bypass line: in an emergency

The static bypass is a support device aimed at ensuring power continuity in the event of inverter failure. In the event of N UPS configured in parallel the failure of a single inverter module should automatically exclude it from the parallel system, ensuring the correct operation of the other units and the reliability of the system.

For this reason automatic switching to bypass lines takes place only when there is a serious fault with the inverter or due to external forces, such as

a short circuit downstream of the system.

These events are both rapid and unpredictable and, based on the power available on the line, can generate short circuit currents that can be extremely high. In the event of distributed parallel configurations where N static by-passes are arranged in parallel, minimal differences (even in the order of fractions of a millisecond), can generate uncontrolled transients and current flow between UPS units such as to trigger protection devices or even damage the bypass thyristors.

Riello UPS are equipped with sophisticated parallel control logics that ensure synchronism between the various units arranged in parallel under all operating conditions. The Riello MSB centralised bypass in any case ensures complete immunity from any problem connected with switching synchronism between modules even in the most extreme cases as long as the static module is single and independent.

In addition, differently from a distributed parallel configuration of the same power rating, the centralised bypass can be oversized to guarantee increased overload capacity and the ability to withstand short circuits.

The ventilation system for the MSB static bypass is designed to guarantee operation even in the event of the failure of several fans. In order to constantly monitor the status of the fans, a control circuit can be provided to control the operation of each individual ventilation fan.

### Centralised diagnostics

The use of the MSB centralised bypass centralises the diagnostics and control of the bypass line.

The display provides information concerning the voltage and current supplied and the status of the individual UPS modules (MHU). Differently from a system with distributed bypass, the centralised bypass is equipped with a single disconnection device for the bypass line and

can be provided with an integrated manual bypass. The single disconnection device guarantees that the manoeuvres are carried out quickly and with a minimum margin of error, guaranteeing once again improved system reliability. The MSB bypass provides dedicated housings for

the various remote control systems such as: three-contact relay board (standard), two communications slots and full compatibility with the communications interfaces in the Riello UPS range for UPS in the MHT / MPT ranges.

**PARALLEL CONFIGURATION UP TO 8 UPS UNITS WITH DISTRIBUTED BYPASS**

Parallel architecture to ensure redundancy of the power source.

**+ Flexibility and modularity and no single point of failure**

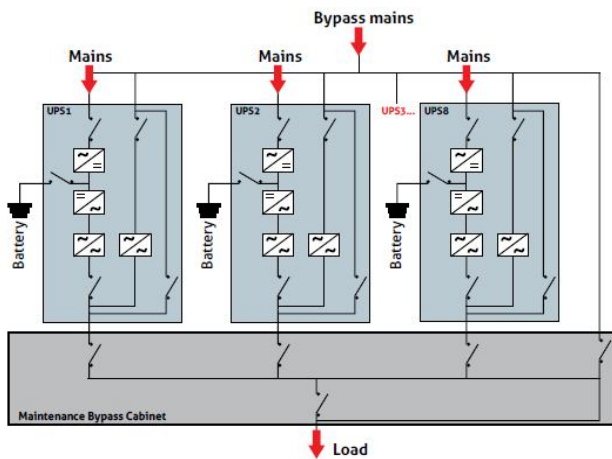

**PARALLEL CONFIGURATION OF UP TO 7 MHU UNITS WITH CENTRAL BYPASS**

Parallel architecture to ensure redundancy of the power source, with autonomous bypass management.

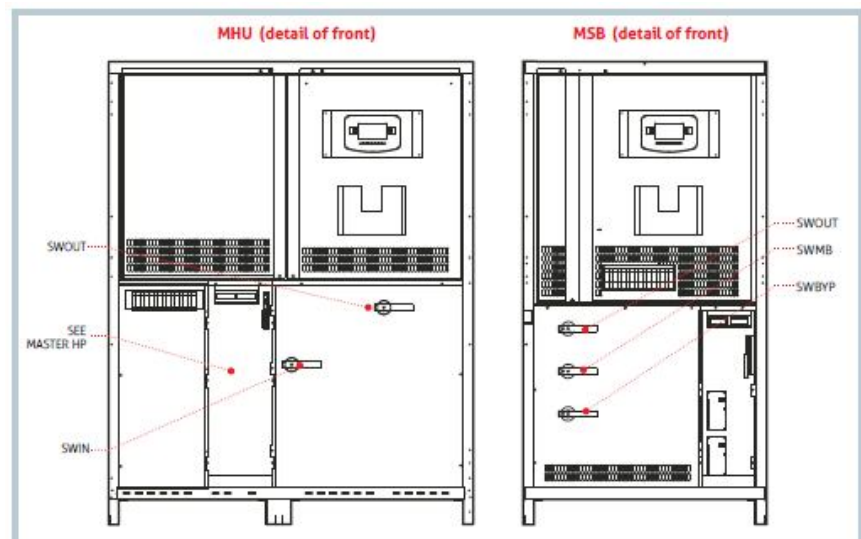
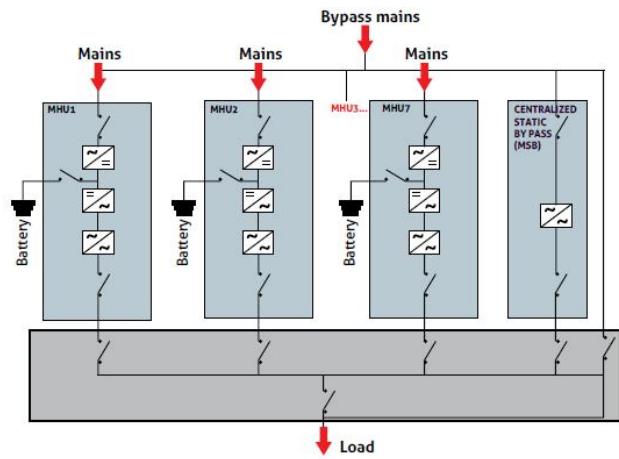

### Technical specification

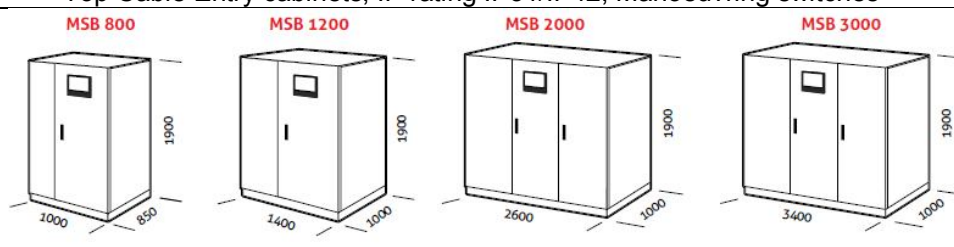
Models	MSB 800	MSB 1200	MSB 2000	MSB 3000
<b>Operating specifications</b>	<b>MSB 800</b>	<b>MSB 1200</b>	<b>MSB 2000</b>	<b>MSB 3000</b>
Nominal power (kVA)	800	1200	2000	3000
Nominal voltage	380-400-415 V <sub>AC</sub> 3-ph+N			
Input voltage tolerance	±15% (selectable from ±10% to 25% from front panel)			
Frequency	50/60Hz			
Frequency tolerance	± 2% (selectable from ±1% to ±6% from front panel)			
Standard equipment provided	Back Feed protection			
Overload	110% for 60'; 125% for 10'; 150% for 1'			
<b>Other features</b>	<b>MSB 800</b>	<b>MSB 1200</b>	<b>MSB 2000</b>	<b>MSB 3000</b>
Noise level at 1m (from 0 to full load)	<65dBA			
Storage temperature	-10°C up to + 50°C			
Operating temperature	0°C - 40°C			
Relative humidity	95% non-condensing			
Max. installation height	1000m at nominal power (-1% power for every 100m above 1000m) - Max 4000m			
Standards	EN 62040-1 general safety requirements; EN 62040-2 electromagnetic compatibility			
Weight (kg)	570	800	1200	2000
Dimensions (w x d x h) (mm)	1000x850x1900	**1400x1000x1900	2600x1000x1900	3400x1000x1900
Communications	Double RS232 + dry contacts + 2 slots for communications interface			
Colour	Dark grey RAL 7016			
IP rate	IP20 (other on request)			
<b>Options</b>				
Software	PowerShield <sup>3</sup> , PowerNetGuard			
Accessories	NETMAN 101 PLUS, NETMAN 102 PLUS, NETMAN 202 PLUS, MULTICOM 301, MULTICOM 302, MULTICOM 351, MULTICOM 352, MULTICOM 401, MULTI I/O, interface kit AS400, MULTIPANEL, RTG 100, 56K MODEM, GSM MODEM			
Product accessories	Top Cable Entry cabinets, IP rating IP31/IP42, Manoeuvring switches			
Dimensions				

\* under certain conditions \*\*1800mm version with switches